



Wind Turbines UK

sales@windturbinesuk.co.uk

WES5 TULIPO

Tel: 0845 269 3083



Wind Turbines UK

0845 269 3083

www.windturbinesuk.co.uk



GENERAL

The WES⁵Tulipo, or popularly called “*Tulipo*”, is the turbine designed for the urban environment and especially for industrial or residential areas. This means that a lot of attention has been given to safety aspects, noise level and design of the *Tulipo*.

An important aspect of the *Tulipo* is the low noise level. The blades have been especially designed for this. The revolutions have been kept low at maximum 140 rpm, where other small turbines (with similar power output) have revolutions of more than 200rpm. The special blades in combination with the relative low rotor speed give the turbine a low noise level and a calm appearance. This in combination with the redundant safety features makes the turbine suitable for urban use.

DESIGN

The *Tulipo* has three blades of 2.5 m (rotor diameter 5 metres), fixed pitch, an upwind rotor with variable speed operation and is suitable for grid-connected operation.

An essential part of the design of the *Tulipo* is the missing of the tail vane. The *Tulipo* is just like its bigger brothers equipped with an active yaw mechanism making a tail vane not necessary.

The *Tulipo* works fully automatic under all weather conditions by means of the specially designed microprocessor controller. At an average wind speed of 3 m/s (is wind force 2!) the turbine will start automatically and starts producing energy.



A gearbox is used between the rotor and the generator. At lower wind speeds the wind turbine operates at variable speed. Above nominal wind speed the turbine operates in constant rotor speed mode and the rotor (and thus the power output) is controlled by means of the stall characteristics of the blades. This is made possible by using an actively controlled rectifier inverter system. The system is grid connected and all the generated power is fed into the grid so no dump load is used. The wind turbine combines the benefits of variable speed operation at low wind speeds with stall control at above nominal wind speed.

The generator assembly is a fully integrated unit consisting of the gearbox, generator and brake. This allows a very compact nacelle design.

All dynamically loaded interfaces from blades to foundation are sturdy flange connections with machined surfaces and use is made of high tensile steel pre-stressed bolt connections. The structural parts are made of steel with high fracture toughness at low temperature.

DOUBLE SAFETY SYSTEM – SAFETY CERTIFICATE

Extra attention has been given to the safety of the *Tulipo* because of its use in the urban environment. The *Tulipo* is the only small turbine with an UL (Underwriter’s Laboratories) Safety Certificate.

The turbine has two independent safety systems:

1. an electro mechanically lifted and spring activated brake on the fast shaft of the generator
2. an emergency yawing system, which will in case of emergency or failure yaw the system out of the wind

Each system has its own control, separate rotor speed sensors and electronics and therefore in case of failure two redundant safety systems are available

Both systems are connected to a battery back-up system making that they also work when the grid fails.

When switched on the turbine goes to stand-by and follows the wind. At an average wind speed of 3m/s it will start turning. When switched off, the rotor is yawed to a 90° degree position and the rotor speed will slow down. Not only yawing can stop the rotor, also the converter can actively reduce the speed of the rotor by means of torque control even when the rotor is up-wind. The electro mechanical brake will be applied after the rotor has stopped. In parked position the rotor will follow the wind at 90° degree position.

BLADE SET

The blades are made of glass fibre reinforced polyester. The aerodynamic design represents state of the art technology. Special attention had the noise emission, resulting in a low source noise level. The blades are moulded and machined with high precision to ensure equal aerodynamic behaviour.



ROTOR

The rotor is a three blade, mounted up-wind of the tower, construction. The “stall” blades have fixed pitch and are connected to the generator-gearbox assembly by two clamping plates. This type of connection ensures that the pitch angle of the three blades is exactly the same preventing aerodynamic imbalance. The rotor is kept up-wind by an active yawing system. At wind speeds of 5 m/s or more the free-yawing forces are strong enough to keep the rotor up-wind and active yawing will be limited to a minimum. The rotor has a glass fibre reinforced polyester nose cone with an attractive aerodynamic shape, fitting close to the nacelle.

THE IGBT INVERTER / CONVERTER



The conversion system uses a standard 8-pole asynchronous generator, controlled by an IGBT inverter system. To optimise the efficiency of the generator the field excitation (voltage) is made dependent of the generator/rotor speed. To control the output-power and to operate the rotor at optimum λ , torque control (current) is used. The electro mechanical brake and the gearbox are directly flanged to the generator making it a compact unit and sealed for external influences as dust, moisture, etc. (protection IP55). The gearbox is splash lubricated giving

reliable operation and minimal maintenance.

NACELLE

The nacelle consists of a thick steel plate supporting the yaw mechanism and generator/gearbox assembly. The nacelle covers, made of glass fibre reinforced polyester, has an attractive aerodynamic shape and can easily be removed for maintenance.

Several sensors, connected to a junction box, are located in the nacelle. A single multi-wire cable is used to connect the sensors to the control system located in the cabinet at the bottom of the wind turbine. Besides the sensors, the junction box doesn't contain any electronics and therefore raising the reliability of the system and simplifying the maintenance.

YAW SYSTEM

The yaw-bearing is an externally geared ring with a pre-stressed four point contact ball bearing. A single DC gear motor, together with a two-stage gearbox with no additional mechanical brake, drives the yawing system. The low mechanical resistance of the yaw system allows free-yawing. This is the self-directing effect that wind rotors show and which keeps them perfectly up-wind in most of the cases. So only when the wind direction sensor signals a too large misalignment, the direction of the rotor will be corrected by active yawing.

TOWER

The nacelle assembly is put on a tubular steel tower. The tower is protected against corrosion through hot dip galvanising and a coating. The wind turbine is standard coloured light green (RAL 6019) and the standard length of the tower is 12 meters. The used steel has a high fracture toughness avoiding brittle fracture at low temperatures.



Tulipo Tower Foot & Cables



Fully Equipped Control Panel with IGBT inverters



Control Cabinet on Foundation



Tulipo's on roof of 6 storey Dutch Pavilion, Expo 2000, Hannover, Germany.



WES⁵TULIPO



TECHNICAL SPECIFICATIONS



The WES⁵ *Tulipo* is especially developed for the urban environment. The output of the 5.2 kW asynchronous generator has been limited to 2.5 kW at a nominal wind speed of only 9 m/s. This turbine with a tip-height of 15 meter has an extremely low noise emission, causes hardly any resonance and can be put on top of office or residential buildings.

GENERAL SPECIFICATIONS

Supplier / producer	WES BV
Life expectancy	Greater than 15 years
Service	maintenance once in two years
Generator Capacity	5.2 kW
Power Output	2.5 kW at 140 rpm 9 - 20 m./s
Cut in wind speed	3 m/s (grid connection necessary)
Cut out wind speed	20 m/s
Nominal wind speed	9 m/s at 140 rpm and 2,5kW power
Maximum wind speed	59,5 m/s (IEC 61400-1 class 2).
Yawing	active yawing by means of a yaw motor
Power regulation	fixed pitch stall
Hub height	12.25 m. or 6.25 m.
Number of blades	3
Rotor diameter	5 m.
Type of conversion system	asynchronous generator/variable speed IGBT converter

MATERIAL SPECIFICATIONS

Tower	steel, 12 meters tall, diameter 273 mm
Total weight	approx. 850 kg
Foundation	standard concrete block-system with anchor
Nose, cover	glass reinforced epoxy
Blades	glass reinforced epoxy
Corrosion protection	Total construction is galvanised
Protection	Tower and covers and blades are coated Ral 6019 IP 55

ELECTRICAL SPECIFICATIONS

Power	2,5 kW
Voltage	400V/50Hz 3 phase or 400V/60Hz 3 phase
Connection	grid connected
Converter	PWM inverter (back-to-back inverter)

GENERATOR

Type	a-synchronous
Brake	Spring powered electromagnetic brake of 80 Nm on fast shaft
Harmonics	NEN 11000-3-2- (< 16A)
EMC	EN 55081-1 en EN 55082-2 (CE)



APPLIED STANDARDS

Wind turbine	IEC 61400-2 (wind class 2)
Certification	IEC 61400-22 by UL
Lightning security	NEN 1014
Protection	IEC 529

SAFETY

Safety	(IEC 61400-2) normal safety through central control
Autonomous safety circuit	rpm > 150, stop (brake and emergency yawing)
Safety actions	“Failsafe” brake on fast shaft of generator independent yawing of 90 degrees
Emergency battery	24Vdc/24 Ah for yawing and safety circuit

ENVIRONMENTAL CONDITIONS

Environment temperature	-20 °C tot + 40 °C
Operational temperature	2 °C - + 40 °C
Air humidity	95 %
Noise levels	35 dB(A) on 20 m. distance at 140 rpm (9 m./s) 72 dB(A) at nacelle



Front and side view of the WES⁵ *Tulipo*

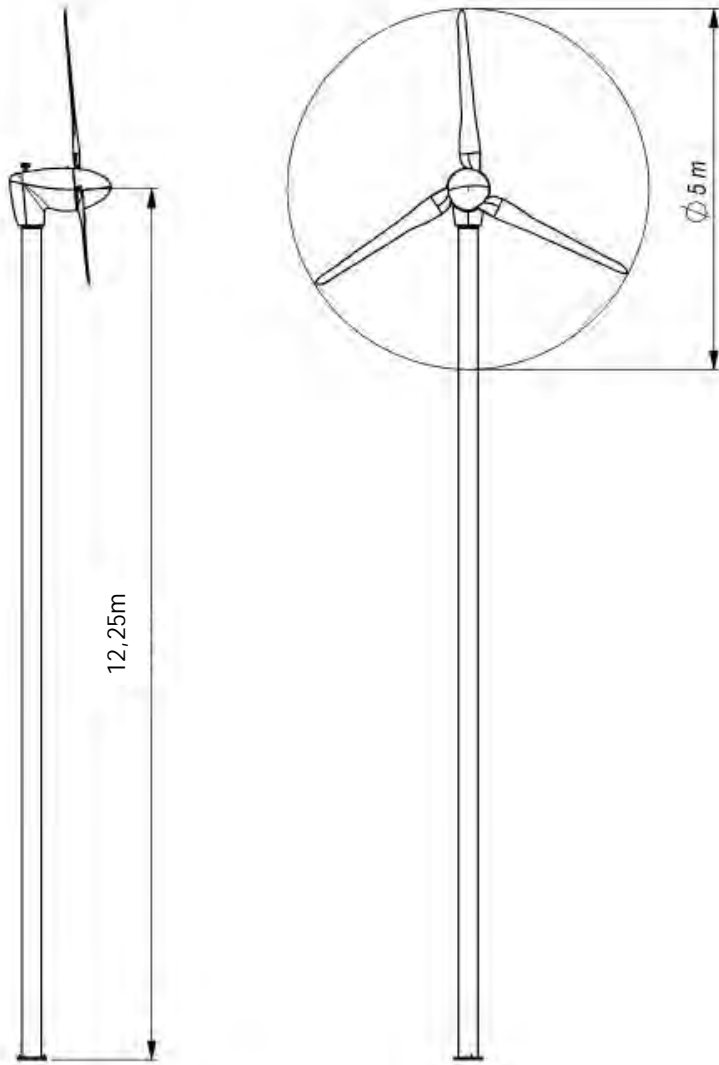

Scale: 1:100